

Standard Dispenser Unit

Our basic Dispenser Unit is designed to fulfill requirements for Helicopter Fuelling Systems worldwide and can be upgraded to project specific requirements.

Our design complies with all international regulations. Most common are DNV, ABS, Lloyd, RMRS, CAP 437, NOG and OSG. Filtration system is approved according to EI 1581 and EI 1583. Top grade materials and design solutions make our units virtually maintenance free, safe and easy to operate under all weather conditions.



For further information email aviation@imenco.com

Contact us for additional information or to get a quotation. Send an email to aviation@imenco.com or find personal contact info on our website.

HELICOPTER REFUELLING SYSTEMS

imenco.com

MATERIALS

- SS316L Baseframe & Driptray
- SS316L Piping, Vessel & Valves
- Enclosure in offshore Alu

ADVANTAGES

- Flow 225 l/min
- Pressure 8.3 Barg
- Design lifetime 25 years

OPTIONS

- 20m – 50m Hose length
- Sample glass
- Storage space for samples & sampling equipment
- Starter panel for El. Motors or pneumatic motors
- Connection for recycle unit
- Underwing nozzle with adapter

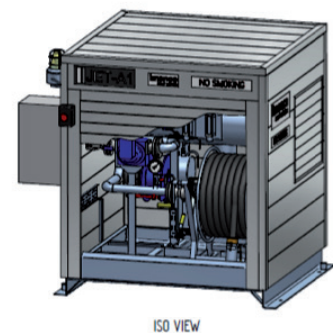
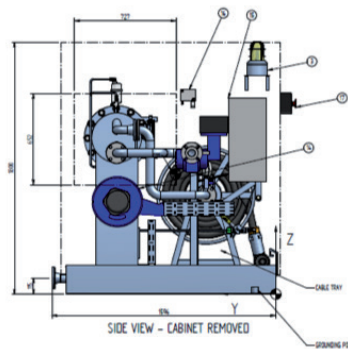
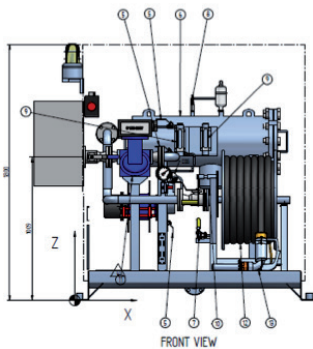

WEIGHT AND DIMENSIONS

Model	Weight (kg) Dry/Wet	L (mm)	W (mm)	H (mm)
IDS1-12-30	825/935	1596	1684	1200
IDS1-15-30	840/950	1596	1684	1500
IDS1-18-30	885/960	1596	1684	1800

For further information email aviation@imenco.com

